



ULUSLARARASI ŞAMPİYONLAR TR YÖS DENEMESİ

🇹🇷 ASLAN HOCA 🇮🇷 YAŞAR OMİD 🇹🇷 RAKİF İMAMLI 🇸🇩 MUHAMMED KNEFATI

ADAYIN/APPLICANTS

ADI/NAME:

SOYADI/SURNAME:

ADAY NUMARASI / CANDIDATE NUMBER:

1. Bu testte 80 soru vardır.
2. Bu test için verilen cevaplama süresi 100 dakikadır.
3. Bu testlerdeki her sorunun bir tek doğru cevabı vardır. Bir soru için birden çok cevap yeri işaretlenmişse, o soru yanlış cevaplanmış sayılacaktır.
4. Cevaplarınızı koyu siyah ve yumuşak bir **KURŞUN KALEMLE** işaretleyiniz. İşaretlerinizi cevap kutucuğunun dışına taşırmayınız. Tükenmez veya dolma kalem kullanmayınız.
5. Bu testler puanlanırken, doğru cevaplarınızın sayısından yanlış cevaplarınızın sayısının dörtte biri düşülecek ve kalan sayı ham puanınız olacaktır.
6. Cevap kâğıdınızı buruşturmayınız, katlamayınız ve üzerine gereksiz hiçbir işaret koymayınız. Değiştirmek istediğiniz bir cevabı, yumuşak bir silgiyle, temizce siliniz ve yeni cevabınızı işaretlemeyi unutmayınız.

1. This test is comprised of 80 questions.
2. The time allowed for this test is 100 minutes.
3. In these tests there is only one correct answer for each question. If more than one alternative is marked, that answer will automatically be considered wrong.
4. You should use a soft, **BLACK PENCIL** to mark the answer sheet. Completely fill in the circle for the answer you have chosen, but make sure your mark does not go beyond the borders of the circle. Do not use any other kinds of pen.
5. In the scoring of the tests, for every four incorrect answers, one correct answer will be deducted, the remainder will be the raw score.
6. Keep the answer sheet flat and do not fold it. Do not make any unnecessary marks on it. If you wish to change an answer, carefully erase it completely with a very soft eraser. Do not forget.

1. Bu testte Sayısal Yetenek alanına ait 40 adet örnek soru vardır.
2. Sınav süresi 50 dakikadır.

1. BİR → 3
İKİ → 3
ÜÇ → 2
DÖRT → 4
BEŞ → ?

A) 1 B) 2 C) 3 D) 4 E) 5

2. $60 \rightarrow 30$
 $30 \downarrow$
 $A \leftarrow 32$
 $A \downarrow$
 $66 \rightarrow 33$
 $33 \downarrow$
 B

⇒ $A + B = ?$

A) 109 B) 99 C) 89 D) 79 E) 69

3.

10	521
16	8421
13	1
14	?

A) 721 B) 127 C) 72 D) 27 E) 7

4.

46	
7	3

23	
5	2

?	
8	4
- A) 48 B) 50 C) 52 D) 58 E) 60

5.

13	12	2	18	8	7
5	9	8	8	7	11
A	4	2	B	6	7
6	2	3	4	5	1

⇒ $A \cdot B = ?$

A) 7 B) 18 C) 20 D) 24 E) 32

6.

HELİN	}	}	82925
MELİS			43029
CEREN			12345
İLKER			62347
MELEK			62320

⇒ $SELİM = ?$

A) 72011 B) 27011 C) 57346
D) 72346 E) 32645

7.

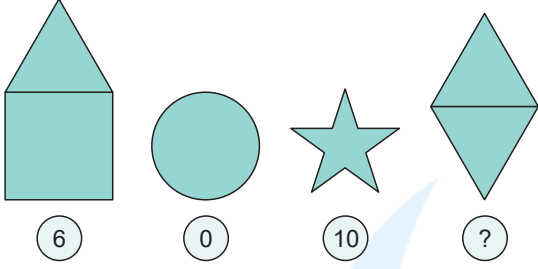

A) 3 B) 4 C) 5 D) 6 E) 7

8.

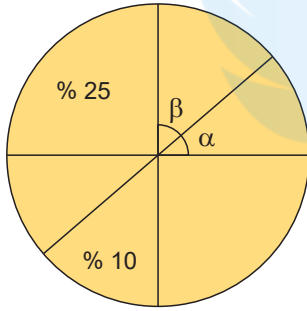

$$\Rightarrow \frac{\alpha}{\beta} = ?$$

A) $\frac{3}{2}$ B) $\frac{1}{2}$ C) 2 D) $\frac{2}{3}$ E) 3

9.

SEVGİ
20020
SAYGIVEFA
0002
HOCAZAFER
02002
?A) CEYLİN B) SABİR C) DENİZ
D) HABER E) ÖZGÜR

10.

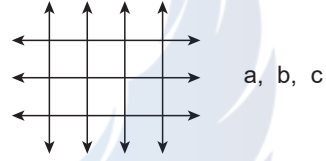
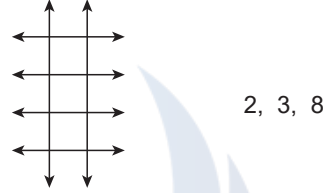
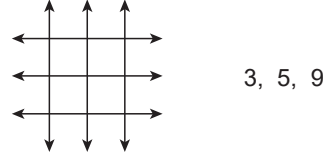

$$\Rightarrow 3^{a+b-c} = ?$$

A) $\frac{1}{9}$ B) $\frac{1}{3}$ C) 1 D) 3 E) 9

11.

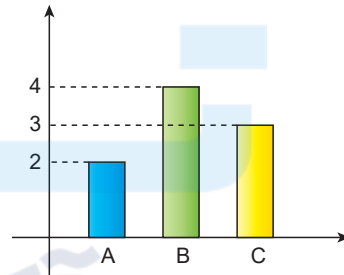

$$A + B + C = 99$$

$$\Rightarrow A + B - C = ?$$

A) 0 B) 11 C) 22 D) 33 E) 44

12.

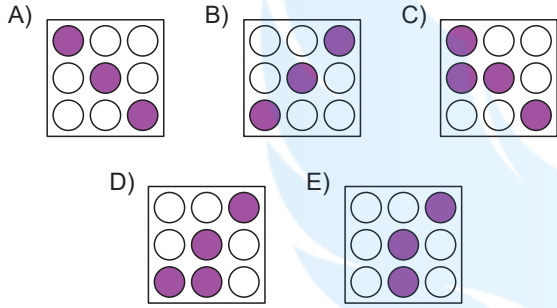
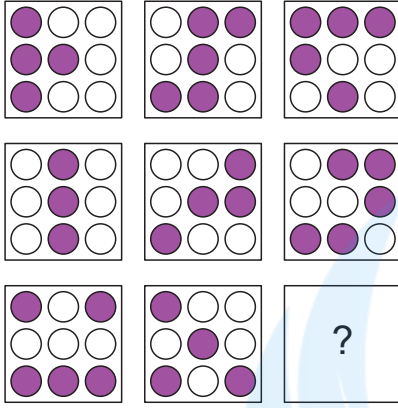

13.

1.	B	A	Ş	A	R	I
2.	A	Ş	A	R	I	B
3.	Ş	A	R	I	B	A
4.	A	R	I	B	A	Ş
⋮	⋮	⋮	⋮	⋮	⋮	⋮
604.	?	?	?	?	?	?

- A) BAŞARI B) ARIBAŞ C) ŞARIBA
D) RIBAŞA E) BAŞAR

14.

BAKÜ → 20

İRAN → 10

TOKYO → 29

SEUL → ?

- A) 20 B) 17 C) 15 D) 13 E) 11

15.

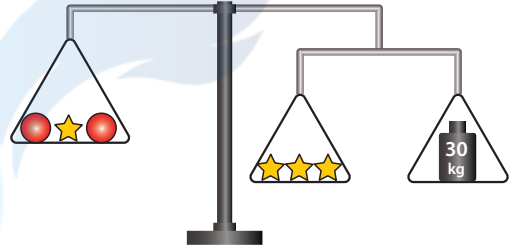

⇒ ● = ?

- A) 10 B) 20 C) 25 D) 30 E) 40

16.

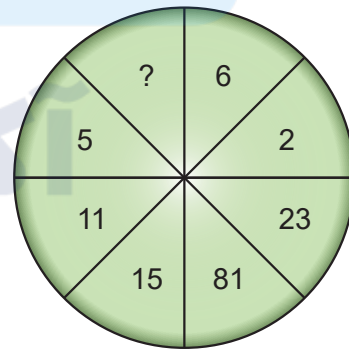

- A) 9 B) 8 C) 7 D) 6 E) 5

17. $a \Delta b = 2a + b$

$\Rightarrow 5 \Delta 8 = ?$

- A) 10 B) 12 C) 14 D) 16 E) 18

18.

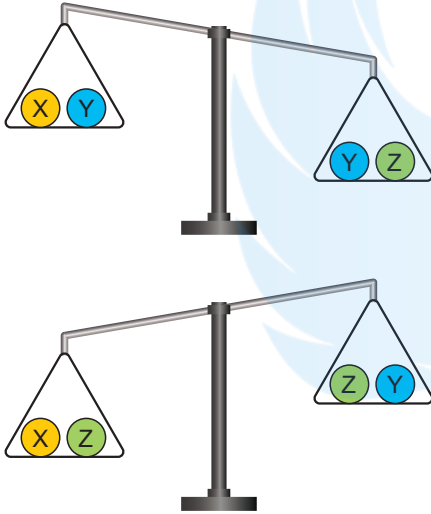

$\Rightarrow ? < ? < ?$

- A) $x < y < z$ B) $z < y < x$ C) $y < z < x$
D) $z < x < y$ E) $y < x < z$

19.

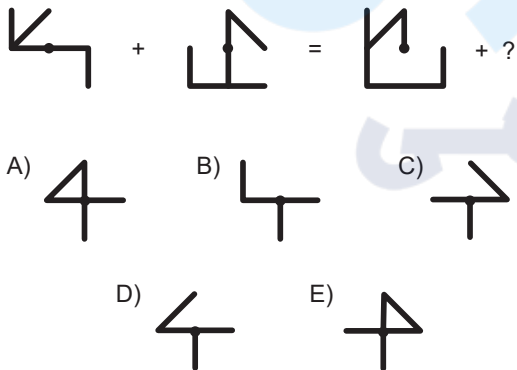

20.

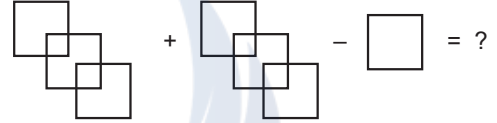
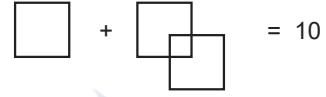
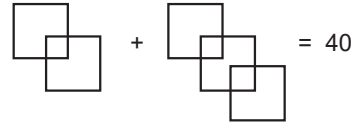

- A) 80 B) 62 C) 60 D) 42 E) 34

21.

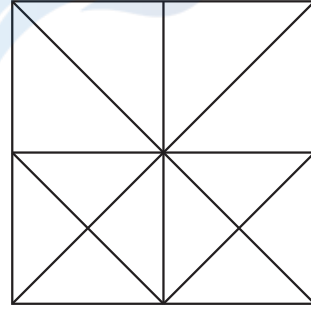

Yukarıdaki şekilde kaç farklı üçgen vardır?

How many triangles are there in the figure?

- A) 25 B) 26 C) 27 D) 28 E) 29

22.

+	a	b	c
a			
b			32
c	16		

x	a	b	c
a			28
b	36		
c			

$\Rightarrow a + b = ?$

- A) 20 B) 24 C) 28 D) 32 E) 40

23.

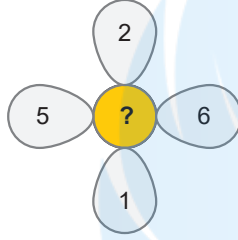
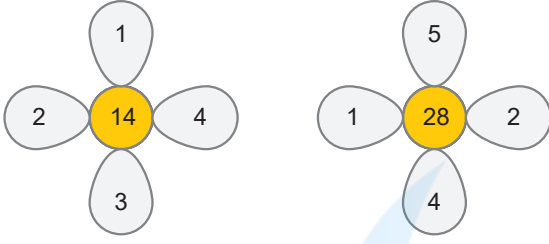

- A) 38 B) 40 C) 42 D) 44 E) 46

24.

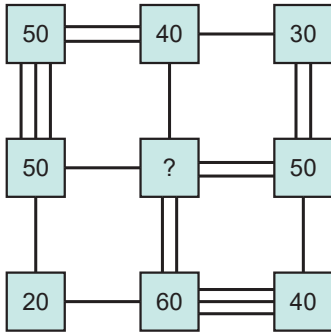

- A) 30 B) 40 C) 50 D) 60 E) 70

25.

$$\begin{array}{r} AA \\ BB \\ CC \\ + \\ \hline 110 \end{array} \quad \begin{array}{r} AA \\ BB \\ - \\ \hline CC \end{array}$$

⇒ A = ?

- A) 3 B) 4 C) 5 D) 6 E) 7

26.

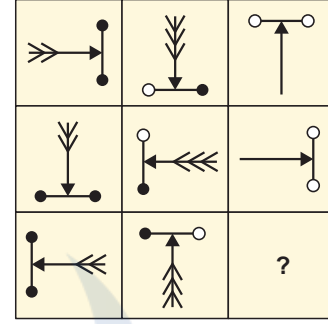

- A)
- B)
- C)
- D)
- E)

27.

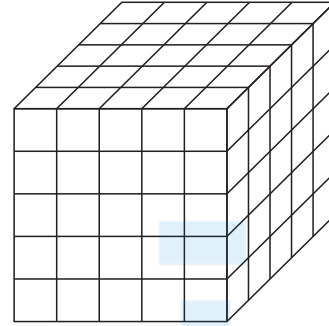

Yukarıdaki büyük küp birbirine eş 125 küçük küpten oluşmaktadır. Büyük küpün herhangi üç yüzeyi kırmızıya boyanıyor.

The big cube above is made of 125 identical smaller cubes is formed. Any three surfaces of the large cube turn red being painted.

İki yüzü kırmızı olan en az kaç küçük küp vardır?

How many small cubes are there with two red faces?

- A) 6 B) 8 C) 10 D) 12 E) 16

28.

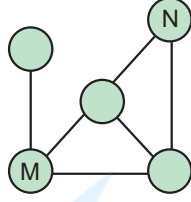
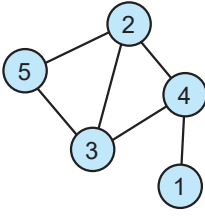

	M	N
A)	3	2
B)	4	5
C)	4	2
D)	3	5
E)	5	4

29.

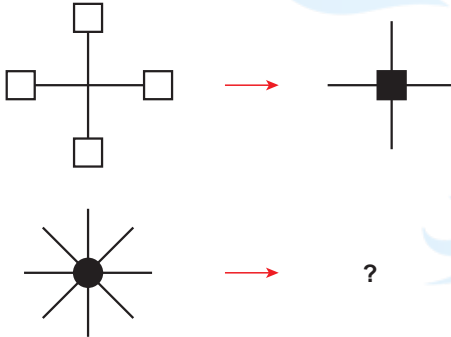

- A) B) C) D) E)

30.

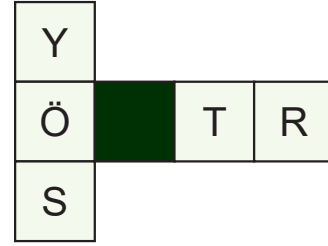

Yukarıdaki şekil küp haline getirilirse hangisi elde edilir?

If the above shape is turned into a cube, which one will be obtained?

- A) B) C) D) E)

31.

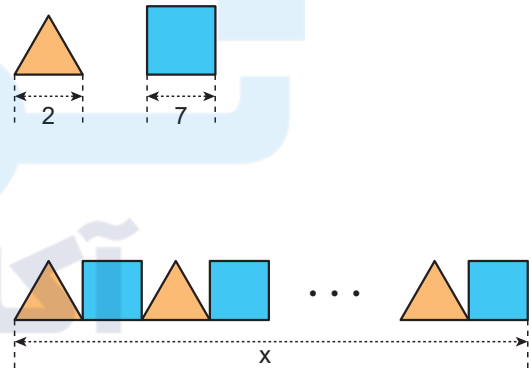

x aşağıdakilerden hangisi olabilir?

Which of the following could x be?

- A) 1881 B) 1299 C) 1453
D) 1923 E) 1938

32.

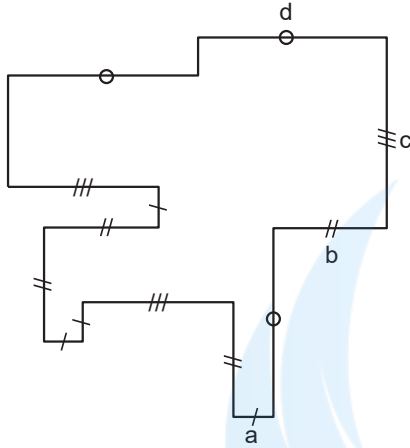

$$a = \frac{b}{2} = \frac{c}{3} = \frac{d}{4}$$

Çevre (Perimeter)= 210 cm

$$\Rightarrow a + b + c + d = ?$$

- A) 68 B) 66 C) 64 D) 62 E) 60

33.

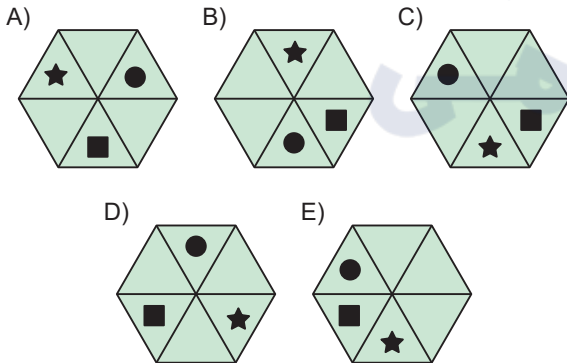
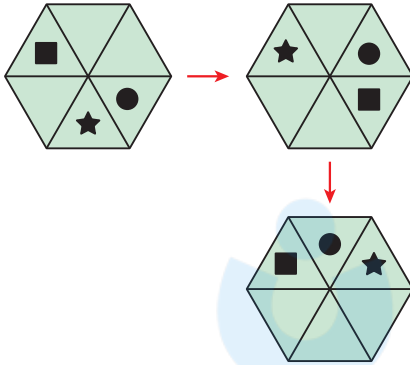

34.

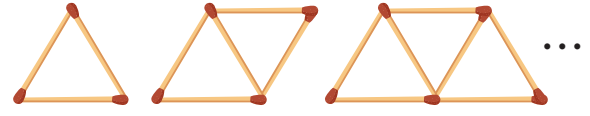

1. adım

2. adım

3. adım

20. adımda kaç kibrit çöpü kullanılmıştır?

How many matchsticks were used in step 20?

- A) 43 B) 41 C) 39 D) 37 E) 35

35.

A	B	C	D	E	F	G
A	C	D	E	F	G	G
C	E	E	D	F	A	B
D	C	D	A	B	A	B
E	F	D	G	B	A	A
F	G	C	F	C	E	B
F	G	A	A	C	A	E

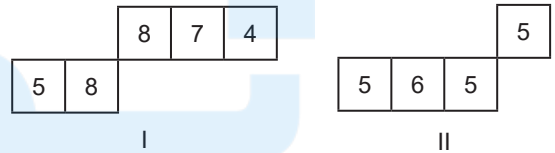

Şekil - I ve II, tablonun farklı birer parçalarıdır. Her rakam bir harfi göstermektedir.

Buna göre, 5858 = ?

Figures I and II are different parts of a table. Each number represents a letter.

Accordingly, what is 5858 = ?

- A) DEDE B) BEBE C) CECE
D) DADA E) BABA

36.

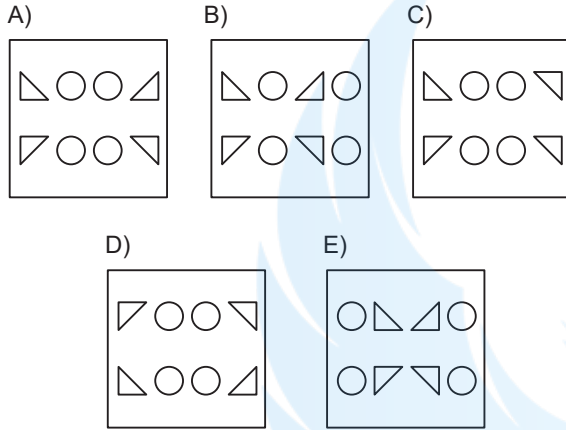
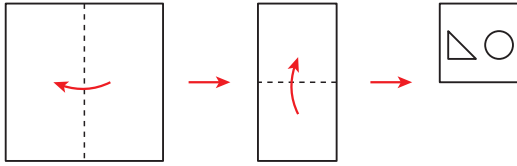

37.

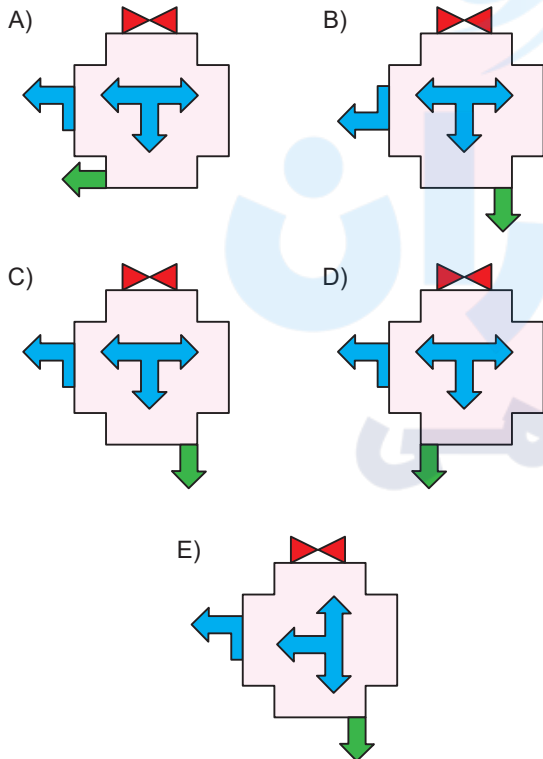
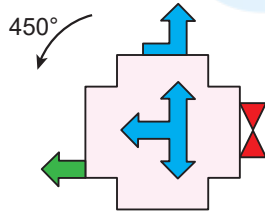

38. Verilen düzlemdeki yapı birim küplerden oluşmaktadır. Bu yapıyı bozmadan büyük bir küp oluşturulmak istense en az kaç birim küp gerekir?

The structure in the given plane consists of unit cubes. If a large cube is to be created without distorting this structure, how many cubes are at least needed?

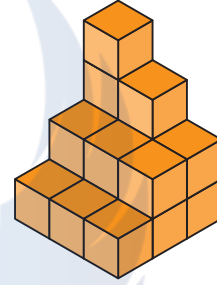

A) 8 B) 9 C) 18 D) 26 E) 46

39.

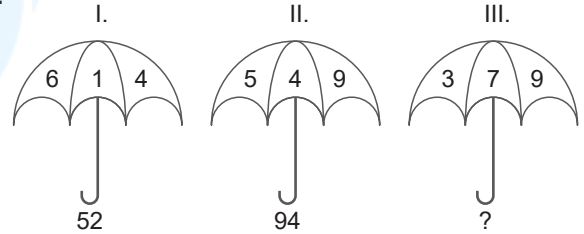

A) 25 B) 34 C) 36 D) 43 E) 46

40. Aşağıdakilerden hangisi farklıdır?

Which of the following is different?

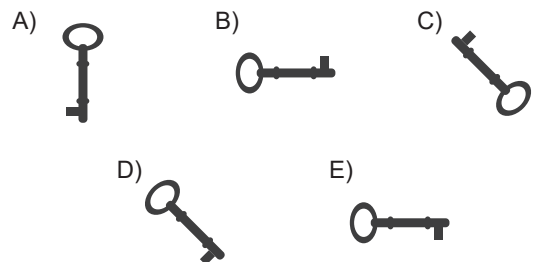

1. Bu testte Temel Matematik alanına ait 40 adet örnek soru vardır.
2. Sınav süresi 50 dakikadır.

1. $\frac{3,9}{1,3} + \frac{0,4}{0,04} = x$

$$\left(\frac{1}{7} + \frac{5}{8} - \frac{3}{4}\right) - \left(\frac{1}{7} + \frac{5}{4} + \frac{5}{8}\right) = y$$

$\Rightarrow x + y = ?$

- A) 11 B) 13 C) 23 D) 33 E) 43

3. $\frac{11 \cdot 6! + 7!}{4! \cdot 5! - 6!} = ?$

- A) 1 B) 3 C) 6 D) 8 E) 12

2. $\frac{7x-6}{\sqrt{5-2\sqrt{6}}} = \sqrt{3} + \sqrt{2}$

$\Rightarrow x = ?$

- A) 0 B) 1 C) 2 D) 3 E) 5

4. $2^{x-3} = 1$

$\Rightarrow x^x \cdot 3^x + 2 \cdot x^6 = ?$

- A) 3^3 B) 3^4 C) 3^5 D) 3^6 E) 3^7

5. $a \cdot b = -12$

$$a \cdot (a - 2b - 4) = 20$$

$$\Rightarrow a + b = ?$$

- A) 6 B) 4 C) -2 D) -4 E) -6

6. $f(3x - 2) - f(x) = kx^2 - 12x + 4$

$$\Rightarrow f(13) - f(5) = ?$$

- A) 144 B) 142 C) 72 D) 71 E) 44

7. $\sqrt{\frac{\sqrt{2} + 4\sqrt{3}}{4} + \frac{63 - 3\sqrt{3}}{3} + \frac{32 - 2\sqrt{2}}{8}} = ?$

- A) 25 B) 20 C) 15 D) 10 E) 5

8. $\sqrt{18 + \sqrt{46 + \sqrt{9}}} = a$

$$\sqrt{20 - \sqrt{20 - \sqrt{20} \dots}} = b$$

$$\sqrt{90 + \sqrt{90 + \sqrt{90} \dots}} = c$$

$$\Rightarrow \frac{c}{a} + b = ?$$

- A) 8 B) 7 C) 6 D) 4 E) 2

9. $f(x + 4) = x^2 + 8x + 16$

$$\Rightarrow f(8) + f(15) = ?$$

- A) f(5) B) f(12) C) f(15)
D) f(17) E) f(23)

10. $\frac{1,1 \cdot 10^{-58} + 0,03 \cdot 10^{-57}}{6 \cdot 10^{-59} + 0,008 \cdot 10^{-56}} = ?$

- A) 1 B) $\frac{1}{2}$ C) $\frac{3}{2}$ D) 2 E) $\frac{5}{2}$

11. • $(x + y) \in \mathbb{Z}$

• $|x - 3| < 4$

• $|y - 2| < 1$

$\Rightarrow \max(x + y) + \min(x + y) = ?$

- A) 9 B) 10 C) 11 D) 12 E) 13

12. $\frac{a^2 + 2ab + b^2}{a + b} \cdot \frac{a^2 - 2ab + b^2}{a - b} = ?$

- A) $a + b$ B) $a \cdot b$ C) $a - b$
D) $a^2 - b^2$ E) $b^2 - a^2$

13. $x^2 + 9x - 2 = 0$

$\Rightarrow (x + 3) \cdot (x + 4) \cdot (x + 5) \cdot (x + 6) = ?$

- A) 330 B) 340 C) 400
D) 420 E) 440

14. $P(x) = 3x^2 + 3x + 1$

$\frac{P(1) + P(2) + P(3) + \dots + P(9)}{37} = k^k$

$\Rightarrow k = ?$

- A) 1 B) 2 C) 3 D) 4 E) 5

15. $a, b, c \in \mathbb{Z}$

$a - b - c = 0$

Buna göre, $a + b + c$ aşağıdakilerden hangisi olabilir?

Which of the following could $a + b + c$ be?

- A) -1923 B) 2024^{2024} C) $2023! + 2023$
D) $2027! + 1$ E) 2025^{2026}

16. • $n(A) = 10$

• $n(A \cup B) = 22$

• $n(A \cap B) = 6$

$\Rightarrow n(B) = ?$

- A) 8 B) 16 C) 18 D) 24 E) 28

$$17. \quad x + \frac{30}{y} = 4$$

$$y + \frac{30}{x} = 2$$

$$\Rightarrow \frac{x}{y} = ?$$

- A) $\frac{1}{2}$ B) 1 C) 2 D) $\frac{2}{3}$ E) $\frac{3}{2}$

18.

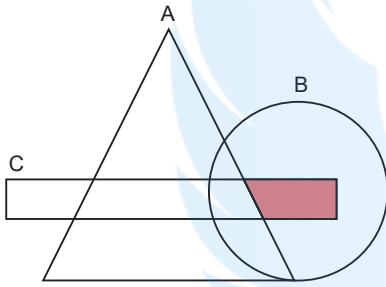

Yukarıda verilen A, B, C kümeleri ile taralı bölgeyi gösteren ifade aşağıdakilerden hangisidir?

The shaded region with the sets A, B, C given above. Which of the following expressions shows?

- A) $(B \cap C) \setminus A$ B) $(A \cap B \cap C)'$
 C) $(A \cap B) \setminus C$ D) $(A \setminus B) \cup (C \cap B)$
 E) $(A \setminus B) \cup C'$

19.

$$\begin{array}{|c|c|} \hline a & b \\ \hline \end{array} = a + b$$

$$\begin{array}{|c|c|} \hline a & b \\ \hline \end{array} = a - b$$

$$\begin{array}{|c|c|} \hline 3x & 1 \\ \hline \end{array} = \begin{array}{|c|c|} \hline 21 & x \\ \hline \end{array}$$

$$\Rightarrow x = ?$$

- A) 2 B) 3 C) 4 D) 5 E) 6

20.

$$\frac{P(x)}{x-4} = \frac{\quad}{3}$$

$$\frac{P(x+2)}{x-2} = \frac{\quad}{k}$$

$$\Rightarrow k = ?$$

- A) 15 B) 12 C) 9 D) 6 E) 3

21.

$$\frac{a}{b} = \frac{b}{c} = \frac{c}{d} = 2$$

$$\Rightarrow \frac{a+c}{d} = ?$$

- A) 10 B) 9 C) 8 D) 4 E) 2

22.

$$\begin{array}{r} ABC \\ BCA \\ CAB \\ + \\ \hline 777 \end{array}$$

$$\begin{array}{r} EF \\ FE \\ + \\ \hline 99 \end{array}$$

$$\Rightarrow (A + B + C) - (E + F) = ?$$

- A) -3 B) -2 C) 0 D) 2 E) 3

23. $9m + \sqrt{3m + n} = 41$

$$3n - \sqrt{3m + n} = 34$$

$$\Rightarrow m \cdot n = ?$$

- A) 52 B) 50 C) 48 D) 42 E) 38

24. $3x + 4y + z = 60$

$$4x - y - 2z = 5$$

$$x + 5y + 9z = 7$$

$$\Rightarrow x + y + z = ?$$

- A) 9 B) 8 C) 6 D) 4 E) 2

25. a, b ve c asal sayı

a, b and c are prime numbers

$$41^{a-b} = c$$

$$\Rightarrow c - a \cdot b = ?$$

- A) 41 B) 40 C) 36 D) 35 E) 34

26.

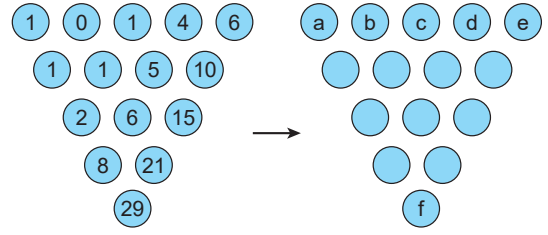

$$\{a, b, c, d, e\} = \{1, 2, 3, 4, 5\}$$

$$\Rightarrow \min(f) = ?$$

- A) 51 B) 46 C) 44 D) 35 E) 34

27. BBB üç basamaklı bir doğal sayı olmak üzere,

BBB is a three-digit natural number,

$$1 \star 2 \rightarrow 3$$

$$1 \star 2 \star 3 \rightarrow 6$$

$$1 \star 2 \star 3 \star 4 \rightarrow 10$$

$$1 \star 2 \star 3 \dots \star A \rightarrow BBB$$

$$\Rightarrow \frac{A+B}{A-B} = ?$$

- A) 4,2 B) 1,4 C) 1,3 D) 1,2 E) 0,6

28. $a + b - c = 3$

$$\Rightarrow \frac{2^a \cdot 2^b}{2^c} = ?$$

- A) 2 B) 4 C) 8 D) 16 E) 32

29. $|x - 3| + |6 - 2x| = 2025$

$$\Rightarrow \sum x = ?$$

- A) 4050 B) 2025 C) 6 D) 3 E) 0

30. • $(A \cap B) \setminus C = \{a, b\}$

• $(A \cap C) \setminus B = \{d, e\}$

• $A \setminus B = \{c, d, e, f\}$

$$\Rightarrow A \setminus C = ?$$

- A) $\{a, b\}$ B) $\{e, f\}$ C) $\{c, d, e, f\}$
D) $\{a, b, c, f\}$ E) $\{a, b, c, d, e, f\}$

31.

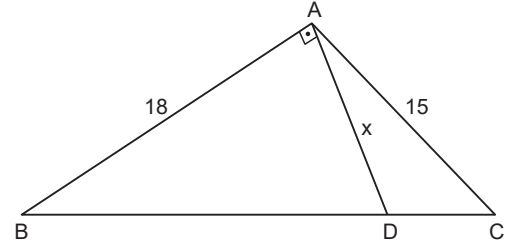

$$[AB] \perp [AD], \quad |BD| = 2|DC|$$

$$|AB| = 18 \text{ cm}, \quad |AC| = 15 \text{ cm}$$

$$\Rightarrow |AD| = ?$$

- A) 8 B) 6 C) 5 D) 4 E) 3

32.

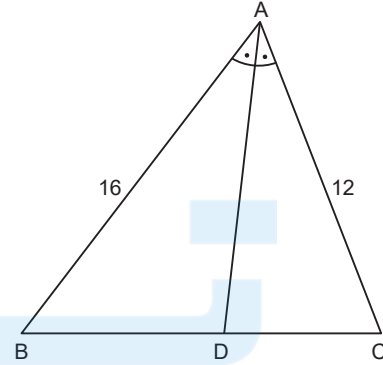

$$ABC \text{ bir üçgen (triangle), } m(\widehat{BAD}) = m(\widehat{DAC})$$

$$|BC| = 14 \text{ cm}, \quad |AB| = 16 \text{ cm}, \quad |AC| = 12 \text{ cm}$$

$$\Rightarrow \text{Çevre}(ADC) = ?$$

$$\text{Perimeter (ADC)} = ?$$

- A) 18 B) 20 C) 22 D) 23 E) 30

33.

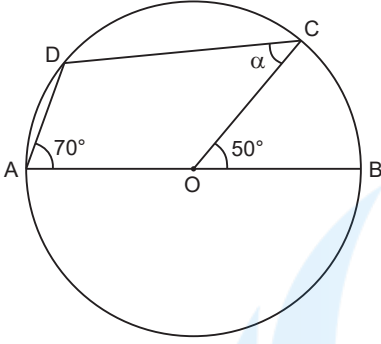

$|AB|$, O merkezli çemberin çapı
 $m(\widehat{COB}) = 50^\circ$, $m(\widehat{DAB}) = 70^\circ$, $m(\widehat{DCO}) = \alpha$

$\Rightarrow \alpha = ?$

- A) 40 B) 45 C) 50 D) 55 E) 60

34.

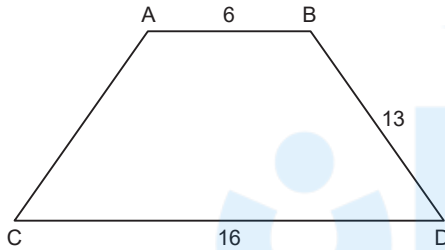

ABCD ikizkenar yamuk (isosceles trapezoid) olmak üzere

$|AB| = 6$ br, $|BD| = 13$ br, $|CD| = 16$ br

$\Rightarrow A(ABCD) = ?$

- A) 112 B) 122 C) 132 D) 144 E) 155

35.

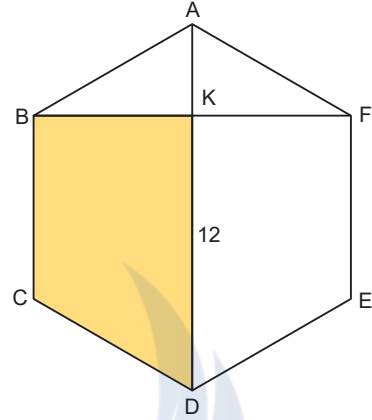

ABCDEF düzgün altıgen (regular hexagon)

$|KD| = 12$ br

\Rightarrow Taralı Alan = ?

Shaded Area = ?

- A) $56\sqrt{3}$ B) $40\sqrt{3}$ C) $12\sqrt{3}$
 D) $10\sqrt{3}$ E) $8\sqrt{3}$

ASLAN HOCA YÖS

36.

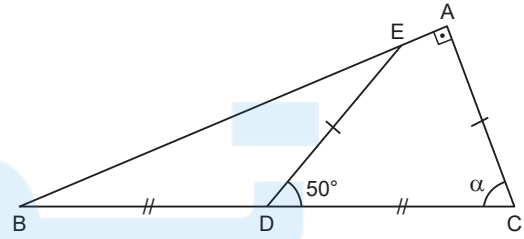

BAC dik üçgen (right triangle), $[BA] \perp [AC]$

$|BD| = |DC|$, $|DE| = |AC|$, $m(\widehat{CDE}) = 50^\circ$

$\Rightarrow \alpha = ?$

- A) 30 B) 45 C) 50 D) 60 E) 70

37.

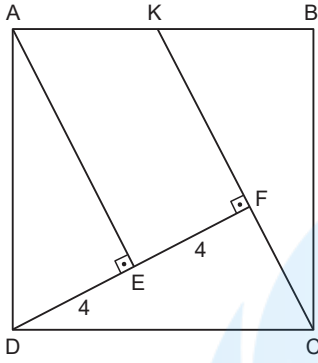

ABCD kare (square), $|DE| = |EF| = 4$ cm

KFC doğrusal, $|KC| = x$ br

$\Rightarrow x = ?$

- A) 5 B) 6 C) 8 D) 10 E) 12

39.

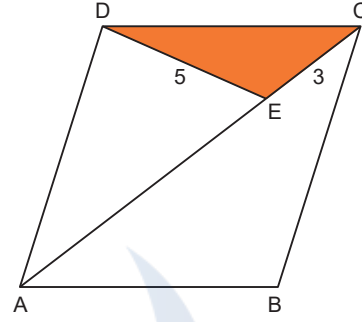

ABCD bir eşkenar dörtgen (equilateral quadrangle)

$[AC]$ köşegen (diagonal)

$|DE| = 5$ cm, $|EC| = 3$ cm, $A(DEC) = 6$ cm²

$\Rightarrow |AE| = ?$

- A) 10 B) 9 C) 8 D) 7 E) 6

38.

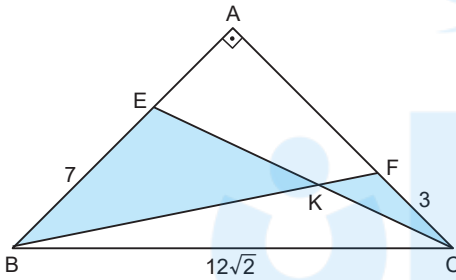

$[AB] \perp [AC]$, $[BF] \cap [EC] = [K]$

$|BE| = 7$ birim, $|FC| = 3$ birim

$|BC| = 12\sqrt{2}$ birim, $|AB| = |AC|$

Buna göre, taralı üçgensel bölgelerin çevreleri toplamı kaç birimdir?

Accordingly, the perimeters of the shaded triangular regions are. How many units in total?

- A) 20 B) 28 C) 32 D) 38 E) 45

40.

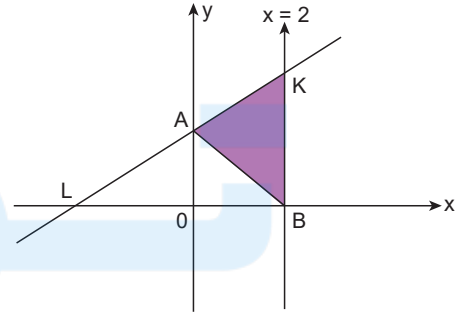

$A(0, 2)$, $L(-4, 0)$

$\Rightarrow A(ABK) = ?$

- A) 2 B) 3 C) $\frac{7}{2}$ D) 4 E) $\frac{9}{2}$